



ELIS PLZEŇ a. s.

Product application, installation and service manual

Ultrasonic heat meter SONOTHERM SN3030,
SONOTHERM SN3040

Page 1 of 28

Ultrasonic heat/cold meter

SONOTHERM SN3030, SONOTHERM SN3040



**CONTENT**

1. APPLICATION	3
2. MEASUREMENT PRINCIPLES	3
2.1 Measuring part of ultrasonic flow meter	3
2.2 Measuring part of calorimeter	5
3. TECHNICAL DESCRIPTION	5
3.1 General description	5
3.2 Meter connection to heating system	6
3.3 Meter design	6
3.3.1 Ultrasonic sensor UC 3.0 including terminal box	6
3.3.2 Ultrasonic sensor UC 4.0 including terminal box	7
3.3.3 Electronic accessory to flow meter	8
3.3.4 Electronic accessory to calorimeter	9
3.3.5 Safety arrangements for commercial meters	9
4. TECHNICAL PARAMETERS	10
4.1 Rated inner diameters and limit flow rates for sensor UC 3.0	10
4.2 Rated inner diameters and limit flow values for sensor UC 4.0	11
4.3 Selection of correct sizes of flow sensors UC 3.0 and UC 4.0	12
4.4 Technical specifications of flow metering part	12
4.5 Communication	12
4.6 Basic technical characteristics of the system	13
4.7 Optional calorimeter accessories	13
5. METER APPLICATION DIRECTIONS AND RULES	14
5.1 Application directions and rules for sensor UC 3.0	14
5.2 Application directions and rules for sensor UC 4.0	16
5.3 Data processing electronic unit	18
5.4 Resistance temperature sensor	18
6. METER ASSEMBLY AND INSTALLATION RULES	19
6.1 Data processing electronic unit MTU 2.00	19
6.2 Electrical connections	20
6.3 Ultrasonic sensors UC 3.0 and UC 4.0	20
6.4 Mechanical connections	20
7. OPERATIONAL START AND METER CONTROL	21
7.1 Flow metering section	21
7.2 Calorimetric section	21
7.3 Displayed data and information	21
8. WARRANTY AND POST-WARRANTY SERVICES	25
8.1 Warranty services	25
8.2 Post-warranty services	25
9. TESTING	25
10. CALIBRATION AND VERIFICATION	25
11. ORDERING	26
12. PACKING	26
13. PRODUCT ACCEPTANCE	26
14. WARRANTY CONDITIONS	26
15. RATING PLATES	26



1. APPLICATION

The meter system SONOTHERM SN3030, SONOTHERM SN3040 is intended for measurement of absolute heat/cold quantities (energy) transferred by water in closed-circle heating/cooling systems. It can be used as commercial meter to determine the heat/cold quantities used or transferred at heated/cooling premises, heat-exchanger stations or at heat/cold-generating plants. The system consists of a flow-measuring section (ultrasonic flow meter) and an electronic calorimeter including the necessary data processing and archiving facility.

2. MEASUREMENT PRINCIPLES

2.1 Measuring part of ultrasonic flow meter

The flow meter section is based on a single-channel "transit-time" impulse method where the flow rate of the measured liquid is determined from the flight time of ultrasonic signal between the sensor probes. The ultrasonic signal is sent and flow-rate measurements are performed in turns in and against the flow direction whereby the error due to non-symmetric positions of the ultrasonic probes is eliminated.

The ultrasonic signal propagation time in the flow direction in flow sensor UC 3.0 is defined by the equation

$$t_1 = \frac{l}{c + v \cdot \cos \alpha} + \frac{l_1}{c_1} \quad [s]$$

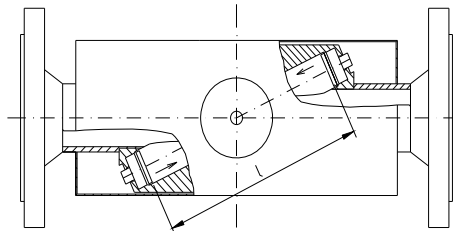

where

- l - distance between the head parts of ultrasonic probes [m]
- c - signal propagation speed in the given liquid [m/s]
- v - flow speed of the measured liquid [m/s]
- l_1 - aggregate thickness of bottom parts of both probes [m]
- c_1 - signal propagation speed in the probe material [m/s]

When the ultrasonic signal travels in the direction against the flow, the expression for the signal propagation time t_2 differs from t_1 in that the flow speed is negative:

$$t_2 = \frac{l}{c - v \cdot \cos \alpha} + \frac{l_1}{c_1} \quad [s]$$

Parameters l and c_1 are constants for the given sensor probe.

The ultrasonic signal propagation speed can be expressed as follows:

$$v_1 = c + v \cdot \cos \alpha \quad \text{for measurements in the flow direction}$$

$$v_2 = c - v \cdot \cos \alpha \quad \text{for measurements against the flow direction}$$

The difference between the ultrasonic signal propagation speeds in and against the flow direction is proportional to the liquid flow speed v [m/s].



$$v = \frac{v_1 - v_2}{2 \cdot \cos \alpha}$$

The instantaneous flow rate can be determined using the equation:

$$q = v \cdot s \cdot k(v) \quad \left[\text{m}^3 / \text{s} \right]$$

- where v - liquid flow speed [m/s]
 s - sensor cross-section [m²]
 $k(v)$ - correction coefficient (a function of the instantaneous liquid speed).
 This coefficient modifies the resulting q with respect to the liquid flow speed profile in the sensor.

The ultrasonic signal propagation time in the flow direction in flow sensor UC 4.0 is defined by the equation

$$t_1 = \frac{l}{c + v} + \frac{l_1}{c_1} + \frac{l_2}{c} \quad \left[\text{s} \right]$$

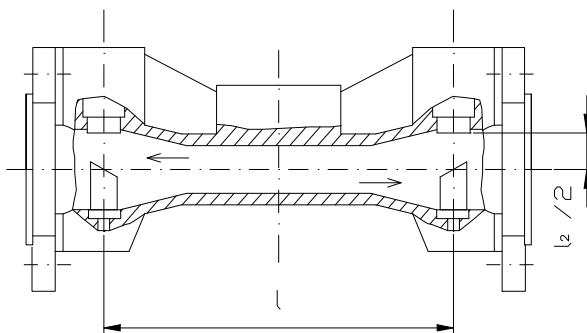

- where l - axial distance between the reflectors [m]
 c - signal propagation speed in the given liquid [m/s]
 v - flow speed of the measured liquid [m/s]
 l_1 - aggregate thickness of bottom parts of both probes [m]
 c_1 - signal propagation speed in the probe material [m/s]
 l_2 - dimension (see the above drawing)

When the ultrasonic signal travels in the direction against the flow, the expression for the signal propagation time t_2 differs from t_1 in that the flow speed is negative:

$$t_2 = \frac{l}{c - v} + \frac{l_1}{c_1} + \frac{l_2}{c} \quad \left[\text{s} \right]$$

Parameters l_1 and c_1 are constants for the given sensor probe.

The ultrasonic signal propagation speed can be expressed as follows:

- $v_1 = c + v$ measurements in the flow direction
 $v_2 = c - v$ measurements against the flow direction

The difference between the ultrasonic signal propagation speeds in and against the flow direction is proportional to the liquid flow speed v [m/s].

$$v = \frac{v_1 - v_2}{2}$$

The instantaneous flow rate can be determined using the equation:

$$q = v \cdot s \cdot k(v) \quad \left[\text{m}^3 / \text{s} \right]$$

- where v - liquid flow speed [m/s]
 s - sensor cross-section [m²]
 $k(v)$ - corrective coefficient (a function of the instantaneous liquid speed).
 This coefficient modifies the resulting q with respect to the liquid flow speed profile in the sensor.



2.2 Measuring part of calorimeter

The calculation of the heat power value uses the following formula; it is assumed that the heat exchanger is absolutely tight and no heating water is being extracted from the heating system.

$$q_t = q_m \cdot [i_1(t_1) - i_2(t_2)] = q_v \cdot \rho(t) \cdot [i_1(t_1) - i_2(t_2)]$$

with the following instantaneous parameter values:

q_t	- heat power transferred by heating water	[J/h]
q_m	- mass flow rate of heating water	[t/h]
q_v	- volume flow rate of heating water	[m ³ /h]
$i_1(t_1)$	- enthalpy of water in the feed piping	[J/kg]
$i_2(t_2)$	- enthalpy of water in the return piping	[J/kg]
$\rho(t)$	- specific density of heating water	[kg/m ³]
t	- water temperature at flow-rate measurement spot	[°C]
t_1	- water temperature (higher temperature of medium)	[°C]
t_2	- water temperature (lower temperature of medium)	[°C]

The quantity of heat transferred Q is defined as the integral over time of the instantaneous heat power values:

$$Q = \int_t q_t dt \quad [J]$$

3. TECHNICAL DESCRIPTION

3.1 General description

The meter system SONOTHERM SN3030, SONOTHERM SN3040 determines the heat/cold quantity delivered or transferred by calculation in a calorimetric counter using data on the water volume passed through the ultrasonic flow meter and the water temperatures in the feed and return pipes.

Type designation of meter systems and their component parts:

System	Accessory electronic unit	Flow sensor
SN3030	MTU 2.00	UC 3.0
SN3040	MTU 2.00	UC 4.0

The quantity of heating water passed through the feed or return piping is measured by means of an ultrasonic flow meter. The water temperatures in the feed and return pipes are measured by two resistance platinum temperature sensors Pt 100 or Pt 500. These measured data are processed in a calorimetric counter with LCD display. The operator can select the data to be displayed using a multi-

function control button (see the table defining the display codes in either *Operational* or *Testing modes* on page 21).

Electronic communication with the meter system is possible using either the M-Bus interface (EN 1434-4 standard) or the IR interface on the front panel. The M-Bus signals are connected to the meter terminal board.

In the cases of a line voltage failure, the ultrasonic flow meter will discontinue operation but not the calorimeter where a back-up battery will supply the necessary power. The calorimeter will thus save all hitherto measured data and record the period of power down time. The calorimetric counter also has specific diagnostic functions; it can identify thermometer failures (shorts or open circuits) or their combinations – see the Error codesError codes on page 24.



3.2 Meter connection to heating system

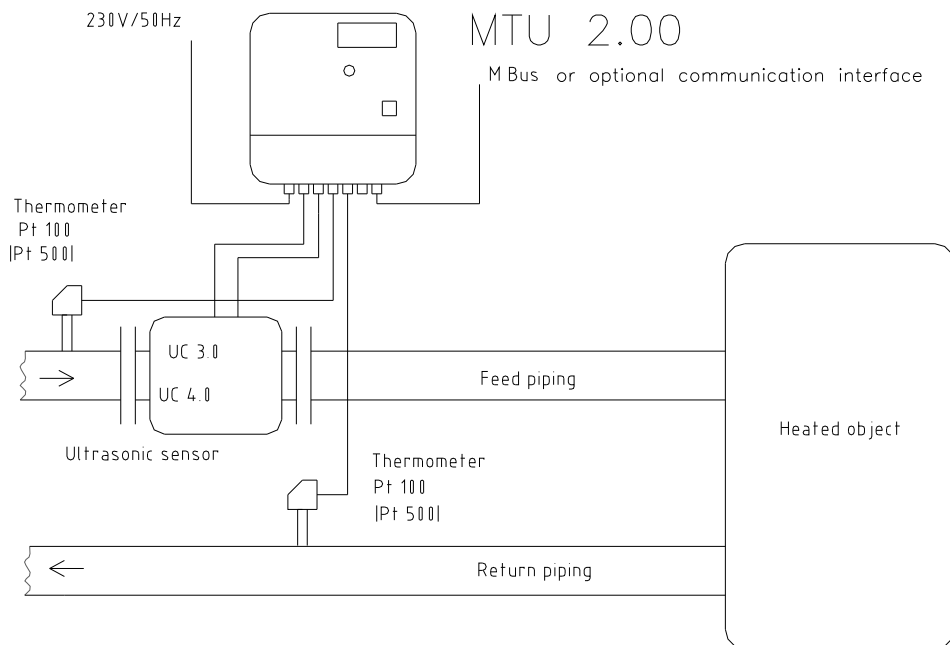

Cooling system: Thermometers for measuring of cold have to be connected to the piping by opposite way. Description of connection is in chapter 6.2.

3.3 Meter design

3.3.1 Ultrasonic sensor UC 3.0 including terminal box

Ultrasonic sensor UC 3.0 is essentially a stainless-steel welded structure consisting of an inner pipe with welded-on pieces holding ultrasonic probes. The inner pipe is provided with flanges made of carbon or stainless steel, as required by the customer. The ultrasonic probes are embedded in hermetic carbon or stainless steel covers. Attached to the sensor cover is a terminal box (an aluminium casting provided with two leadthroughs PG 9 and a special valve preventing condensation inside the box). The terminal box is mounted on the sensor body across a heat-insulation pad. The sensor is painted with powder paint, hue RAL 7035 and the terminal box with paint RAL 7016. The main dimensions of various sensor models are shown in the following table:

PN	Dimension	DN 32	DN 40	DN 50	DN 65	DN 80	
16/40	∅ P [mm]	140	150	165	185	200	
16/40	S [mm]	181	191	206	220	237	
16/40	L [mm]	360	360	360	360	360	
PN	Dimension	DN 100	DN 125	DN 150	DN 200	DN 250	DN 300
16	∅ P [mm]	220	250	285	340	405	460
16	S [mm]	256	285	314	361	419	471
40	∅ P [mm]	235	270	300	375	450	515
40	S [mm]	263	296	321	379	441	499
16/40	L [mm]	360	360	360	450	450	450



Dimensional sketch:

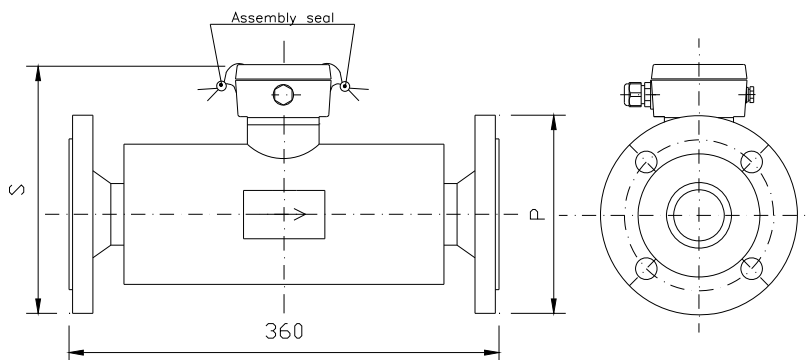

3.3.2 Ultrasonic sensor UC 4.0 including terminal box

Ultrasonic sensor UC 4.0 consists of a body (a casting made of bronze alloy according to Czech standard CSN 42 31 35, RG 5) including two ultrasonic probes and two reflectors. The body can be supplied with either end flanges (CSN 131160.0) or end G-type threads. The sensor is coated with KOMAXIT paint of hue RAL 7035. The sensor assembly further includes a terminal board housed in a cast aluminium box provided with RAL 7016 paint and mounted onto the sensor body across a heat-insulating pad. The sensor terminals can be accessed upon removal of a lid held in position by means of four M4 bolts with hexagonal socket heads. A special valve embedded in the terminal box prevents water humidity from condensation inside the box.

Dimensional sketches:

Sensor with end flanges

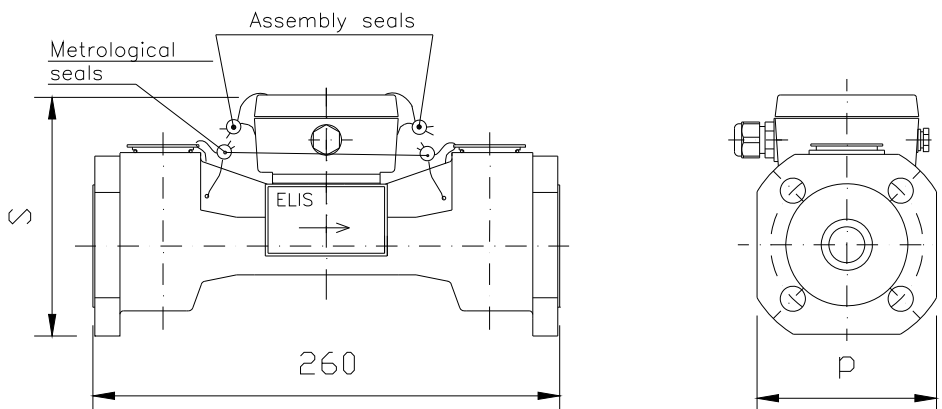

Rated size	R. pressure	S [mm]	P [mm]	m [kg]
DN 25	PN 16	140	□ 100	5,3



Sensor with end threads

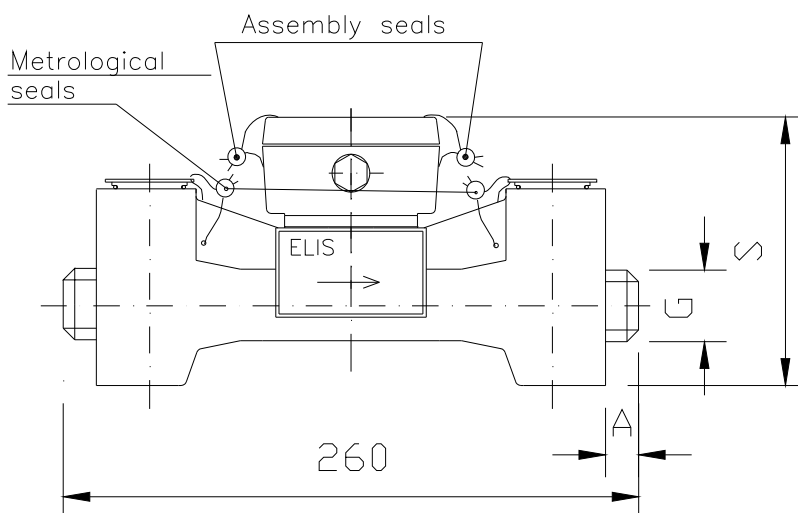

Rated size	R. pressure	End thread	S [mm]	A [mm]	m [kg]
DN 25	PN 16	G 1 1/4"	125	18	4,5

3.3.3 Electronic accessory to flow meter

The electronic accessory to the flow meter is housed in a plastic box with internal metal coating. The calorimetric counter, type MTU 2.00, is located in the same box. The ultrasonic sensor is connected to its electronic accessory by means of two coaxial cables of adequate length.

Regarding function, the electronic accessory to the flow meter can be divided into the following parts:

- circuits isolating the meter probes
- switches controlling the probe signals
- ultrasonic sender
- ultrasonic receiver including sensitivity-control circuitry
- interface circuits communicating with the data processing computer
- computer
- output circuits generating impulses for the calorimetric counter
- circuits of the serial communication line (the flow-meter setting)
- power source.

There is also an adaptive filter eliminating fast changes of instantaneous flow rate resulting from pulsation of the liquid flowing through the piping, actions of the flow-control elements and other disturbing events from outside the piping. In a flow meter of standard design, this filter causes a delay of several seconds of the sensor output data with respect to the actual flow rate in the sensor.

However, the electronic accessory of the ultrasonic flow meter can be modified so as to ensure a very fast response to the quickly changing mass flow data. This modification finds application in systems where instantaneous flow rate needs be measured and monitored as fast as possible, e.g. in heat exchanger and transfer stations where fast regulation processes take place.



3.3.4 Electronic accessory to calorimeter

The electronic calorimetric counter is a modern microprocessor-based device used in combination with an ultrasonic flow meter to measure heat energy for commercial purposes. The calorimeter can process and store large quantities of data so that the user has detailed information on the current status of the measuring point as well as the measured data over long periods of time.

The counter input receives signals from the impulse sender of the flow meter and two temperature sensors. With each impulse from the flow meter received, the temperatures of the incoming and outgoing liquid are measured. The temperature data and flow meter impulses are stored in the internal memory circuits of the counter. The heat energy data are calculated using the data on the temperature difference, flow rate and the associated thermal coefficients; these data are integrated in the counter memory and their aggregate values shown on the counter display.

If the frequency of the output impulses from the flow meter is higher than 1Hz, the impulses (representing the flow volume passed through the meter) are cumulated and the heat/cold measurements are taken once a second.

If the interval between impulses exceeds 60s, each 60s temperature readings are taken and shown on the counter display; but the heat/cold measurement/calculation takes place only after the next impulse from the flow meter is received.

3.3.5 Safety arrangements for commercial meters

Commercial meters, i.e. meters where the measured data are used to determine heat charges to be invoiced to the customer, shall be provided with official marks and seals testifying to the correct meter setting and ensuring meter safety. These marks and seals include:

- System type plate (located on the electronic accessory box) with stick-on labels bearing the official meter verification mark
- Two seals with imprints of official marks on the lids of ultrasonic probes of sensor UC 4.0
- Two seals with imprints of official marks on the electronic accessory box (MTU 2.0) preventing unauthorised opening and manipulation with the meter data or setting.

Upon installation of the complete system SONOTHERM SN3030, SONOTHERM SN3040 at the required measuring location, the duly authorised assembly staff shall secure the system against illegal handling by means of:

- Two assembly seals with imprints of official marks on the terminal box lid of sensor UC 3.0 (UC 4.0)
- Two assembly seals with imprints of official marks on the lids of the temperature sensor housings
- One assembly seal with imprint of official mark on the cover of the terminal box of the accessory electronic unit

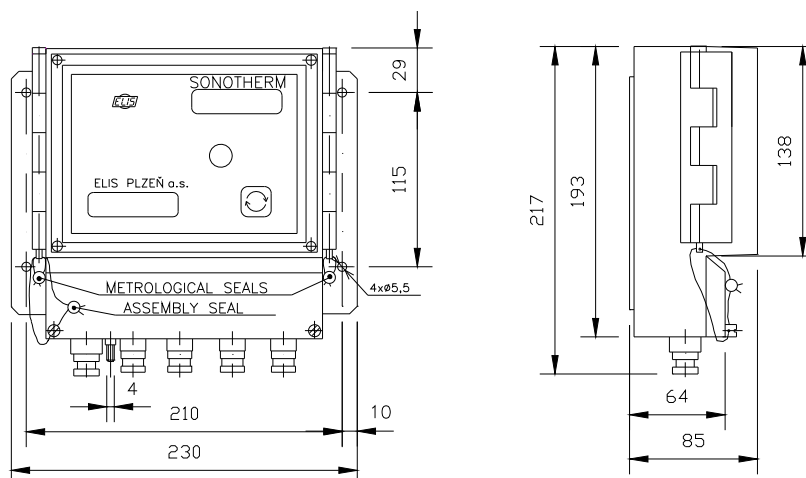



4. TECHNICAL PARAMETERS

4.1 Rated inner diameters and limit flow rates for sensor UC 3.0

The following table shows the limit flow rate values for particular sensor sizes.

DN	32	40	50	65	80	100	125	150	200	250	300
q_s [m ³ /h]	20	32	50	80	150	240	350	500	900	1400	2000
q_p [m ³ /h]	10	16	25	40	75	120	175	250	450	700	1000
q_{min} [m ³ /h]	0.2	0.32	0.5	0.8	1.5	2.4	3.5	5.0	9.0	14	20
q_{NECV} [m ³ /h]	0.07	0.09	0.14	0.22	0.37	0.6	0.9	1.2	2.2	3.5	5

where:

- q_s - overloading (maximum) flow rate
- q_p - continuous (rated) flow rate
- q_{min} - minimum flow rate
- q_{NECV} - minimum flow rate – sensitivity threshold level

The flow rate value upon reaching of which the flow meter starts to indicate and evaluate the measured data is normally set by the manufacturer at q_{NECV} . On customer's request, this threshold level can be set at any other value within the interval $q_{NECV} \div 0.025q_s$.

Pressure losses of ultrasonic sensors UC 3.0:

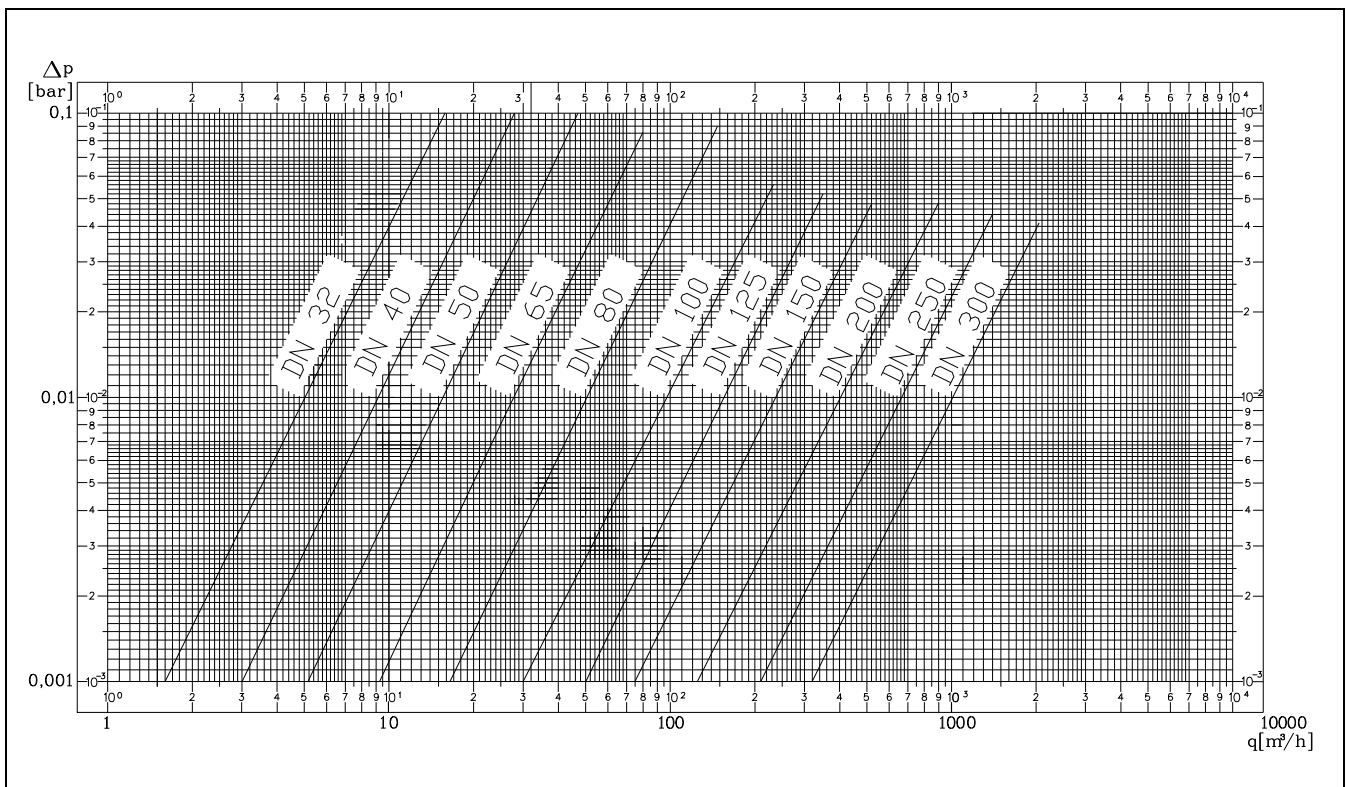



4.2 Rated inner diameters and limit flow values for sensor UC 4.0

The following table shows the limit flow rate values for particular sensor sizes.

DN/diameter of middle part	25/17			25/20		
q_s [m ³ /h]	5	7	12	7	12	20
q_p [m ³ /h]	2.5	3.5	6	3.5	6	10
q_{min} [m ³ /h]	0.05			0.1		
Δp (q_p) [bar]	0.03	0.06	0.17	0.026	0.075	0.2
l [mm]	260 for both flanged and threaded ends					
q_{NECV} [m ³ /h]	0.025			0.035		

where:

q_s - overloading (maximum) flow rate

q_p - continuous (rated) flow rate

q_{min} - minimum flow rate

q_{NECV} - minimum flow rate – sensitivity threshold level

The flow rate value upon reaching of which the flow meter starts to indicate and evaluate the measured data is normally set by the manufacturer at q_{NECV} . On customer's request, this threshold level can be set at any other value within the interval $q_{NECV} \div 0.025q_s$.

Pressure losses of ultrasonic sensors UC 4.0:

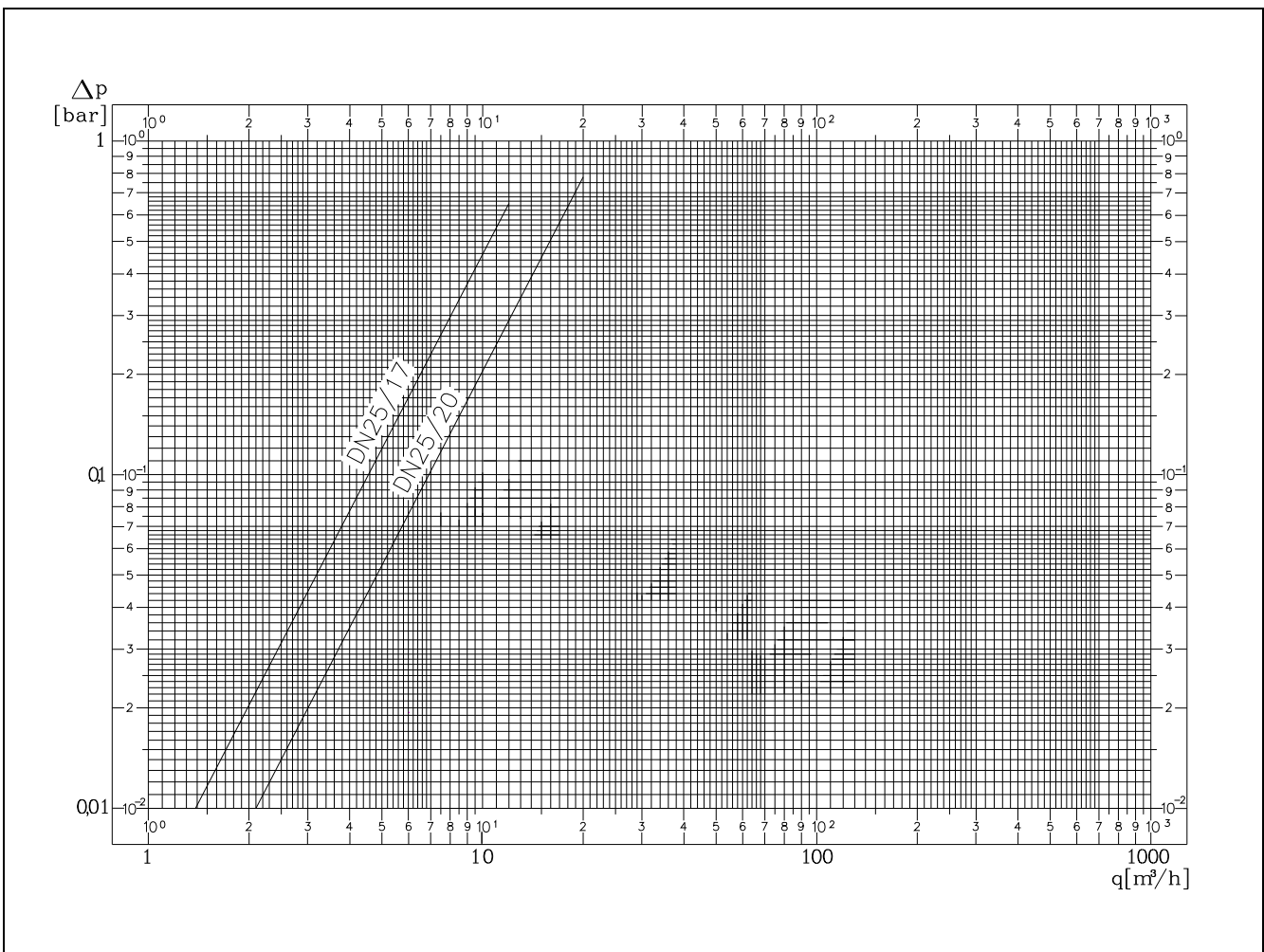



4.3 Selection of correct sizes of flow sensors UC 3.0 and UC 4.0

The size of the flow sensor shall be selected with respect to the parameters of the required measuring location. First of all, the value of the continuous flow rate in the piping should be considered and a sensor with the matching q_p selected using the tables in Sections 4.1 and 4.2 above. Then the pressure loss of the sensor should be taken into account; although the pressure loss is generally very low, it adds up to the total losses in the piping, in particular at higher liquid flow velocities. In the cases where the standard sensor design does not meet the operational requirements, specific settings of parameters q_s a q_{min} for given sensor size can be made on request. In particular meter applications the pressure loss characteristics should be considered with the understanding that q_{min} cannot be set lower without affecting the rated measurement accuracy and the value of q_s for the given sensor size should not exceed the maximum limit value shown in the tables in Sections 4.1 and 4.2.

4.4 Technical specifications of flow metering part

Rated pressure of measured liquid, PN	Flanged-end meter version: 4.0 MPa
	Threaded-end meter version: 1.6 MPa
Temperature of measured liquid	0 ÷ +150°C
Protection class - sensors UC 3.0, UC 4.0	IP 65 (optional IP 67)
Meter installation in piping	Flanges 11 (standard CSN 131160.0), or Screwed fitting with G*-type thread
Sensor cable length	Standard 5 m
	Maximum 100 m
Difference in cable lengths	Maximum 0.1 m

* only with sensor model UC 4.0

4.5 Communication

System SONOTHERM SN3030, SONOTHERM SN3040 is provided with communication interface M-Bus (standard EN1434-4) with the respective signals connected to the meter terminal board, and IR interface accessible via a window in the front panel. The measured data can be transferred using both interface systems.



4.6 Basic technical characteristics of the system

Temperature range (measured liquid)	0 ÷ 190 °C
Temperature difference Δt	3 ÷ 120 °C
Litres per impulse	Programmable within the range of 0.005 ÷ 9,999 l/imp
Display mode	LCD, 7 + 2 digits from zero to nine
Separate electronic data processing unit, model MTU 2.0	
- dimensions (width, height, depth)	230 x 217 x 85 mm
- weight	1.8 kg
- power supply	90 ÷ 260 VAC, 50/60 Hz, or 24 V AC/DC $\pm 10\%$
- back-up power source	Li-battery 3 V
- power requirement	6 VA
- line fuse	T 250 mA, 250 V
- protection against electric shock (CSN 332000-4-4)	Automated disconnection from line voltage in the TN-S network
Ambient temperature	+5 to 55 °C
Relative humidity	80 %
Storage temperature	-10 to 70 °C at relative humidity not exceeding 70 %
Protection class (accessory electronic unit)	IP 65
Data output	M-Bus (standard EN 1434-4, IEC 870) IR optocoupler

4.7 Optional calorimeter accessories

On request, the calorimetric counter can be supplied with the following optional devices/functions:

- display with illuminated background

When using other optional devices, it should be noted that there are two free terminals available (marked as "rez." – reserve) where any of the following signals can be connected:

- impulse output of the "heat energy" or "volume" signals (open-collector output, $U_{CE\ max} = 24\ V$, $I_{CE\ max} = 20\ mA$, impulse length 250 ms)
- impulse input – impulse counter for "hot water" or other signals (contact input, $f_{max} = 12\ Hz$, impulse length 40 ms, max. voltage 3 V)
- communication interface SIOX-Bus (compatible with meters of the model series SWM 820, SWM 690 and other measuring systems based on such devices)
- alarm signal (open-collector output, $U_{CE\ max} = 24\ V$, $I_{CE\ max} = 20\ mA$, impulse length 250 ms).
- protection of sensor IP 67

5. METER APPLICATION DIRECTIONS AND RULES

5.1 *Application directions and rules for sensor UC 3.0*

When selecting the measuring location in the piping, it is necessary to observe certain rules so that the measurement accuracy would not be adversely affected. For sensor UC 3.0, the basic requirements are straight piping sections of the length 5 D at the input side and 3 D at the output side where no flow-disturbing elements should be located, such as 90° bend or pipe sections with smaller or larger diameter.

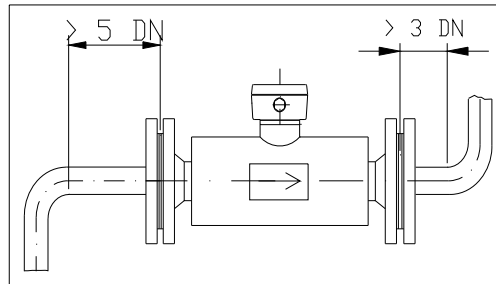

Basic requirements on straight pipe sections at the meter input and output

If there is a pump at the sensor input side, the recommended length of straight pipe section is 20 DN. If there is a fully opened valve, the recommended length of straight piping is 10 DN. If there is a control valve or partially-opened valve or a flap valve, the recommended length of straight piping at the meter input side is 40 DN.

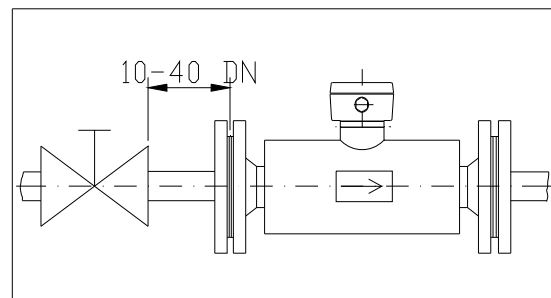
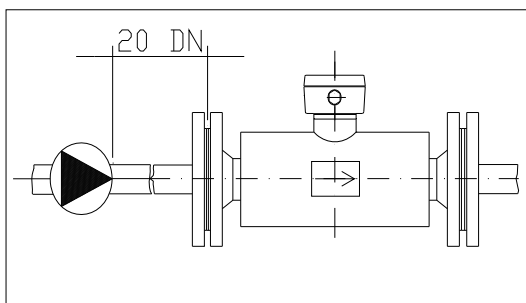

Required straight pipe sections for “disturbances” at the input side of the flow meter

A straight pipe section of the length 3 DN is required for such “disturbances” at the output side.

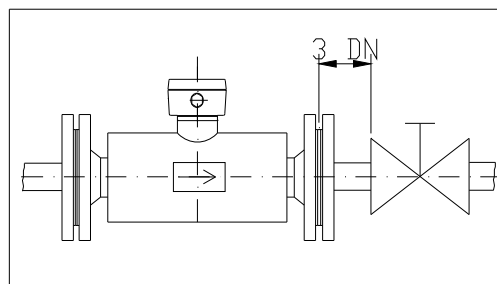

Required straight pipe section for “disturbances” at the output side of the flow meter

In the cases where complete flooding of the water pipe cross-section cannot be guaranteed at all times, the flow sensor can be located at a bottom pocket of the piping to ensure permanent flooding.

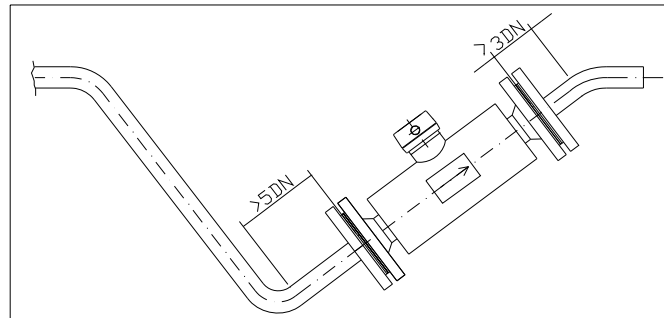

Meter location at a bottom pocket in the piping

If the meter is to be installed in a perpendicular position, the flow direction shall be from the bottom upwards.

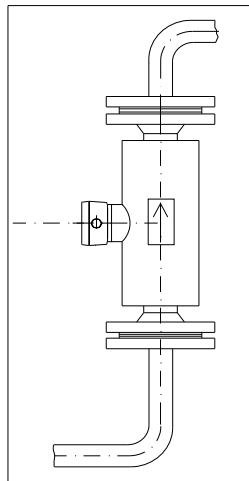

Flow meter installed in a perpendicular position

To ensure correct functioning of the flow meter, the sensor shall always be completely filled with the measured liquid. It shall therefore never be located at a top pocket in the piping or in a perpendicular position with the flow direction downwards, in particular in the cases where there are pipe outlets into the open-air immediately after the measuring spot.

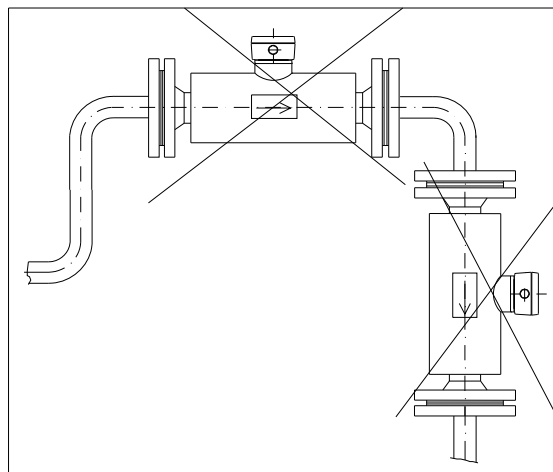

Examples of incorrect placement of the flow meter sensor

Pressure losses in the flow sensors related to liquid flow velocity are shown in the table in Section 4.1. above.

5.2 Application directions and rules for sensor UC 4.0

When selecting the measuring location in the piping, it is necessary to observe certain rules so that the measurement accuracy would not be adversely affected. For sensor UC 4.0, the basic requirements are straight piping sections of the length 5 D at the input side and 3 D at the output side where no flow-disturbing elements should be located, such as 90° bend or pipe sections with smaller or larger diameter.

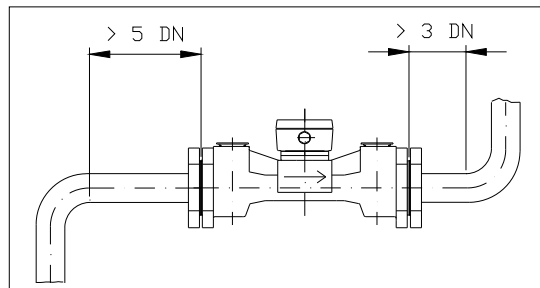

Basic requirements on straight pipe sections at the meter input and output

If there is a pump at the sensor input side, the recommended length of straight pipe section is 20 DN. If there is a fully opened valve, the recommended length of straight piping is 10 DN. If there is a control valve or partially-opened valve or a flap valve, the recommended length of straight piping at the meter input side is 40 DN.

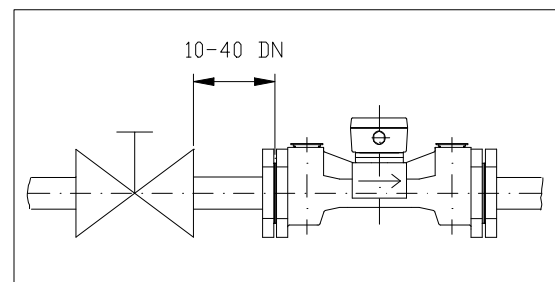
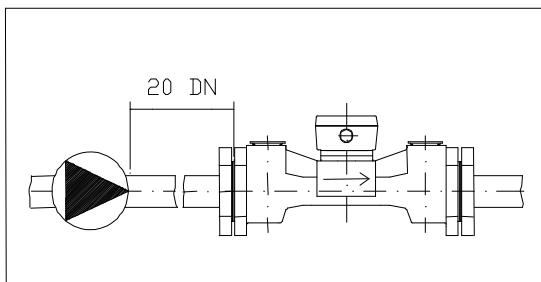

Required straight pipe sections for “disturbances” at the input side of the flow meter

A straight pipe section of the length 3 DN is required for such “disturbances” at the output side.

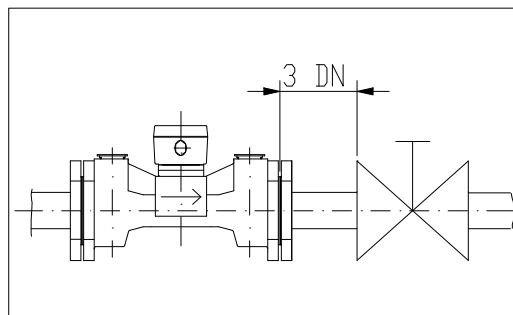

Required straight pipe section for “disturbances” at the output side of the flow meter

In the cases where complete flooding of the water pipe cross-section cannot be guaranteed at all times, the flow sensor can be located at a bottom pocket of the piping to ensure permanent flooding.

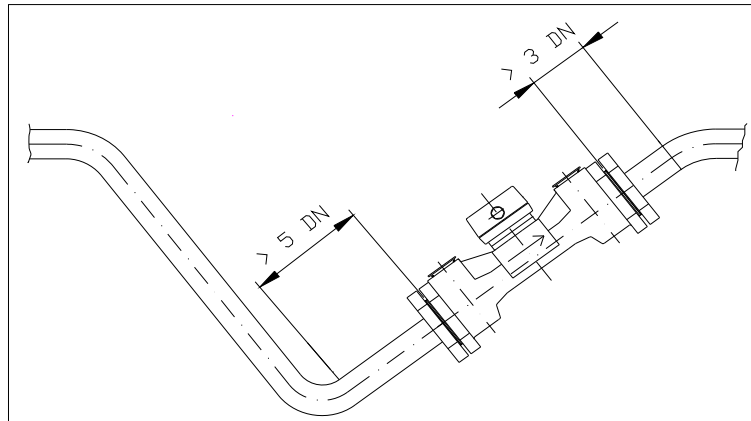

Meter location at a bottom pocket in the piping

If the meter is to be installed in a perpendicular position, the flow direction shall be from the bottom upwards.

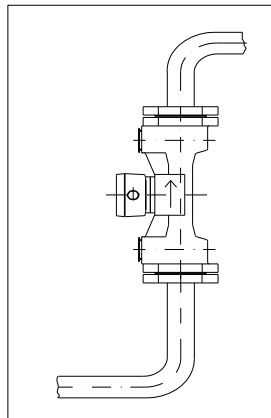

Flow meter installed in a perpendicular position

To ensure correct functioning of the flow meter, the sensor shall always be completely filled with the measured liquid. It shall therefore never be located at a top pocket in the piping or in a perpendicular position with the flow direction downwards.

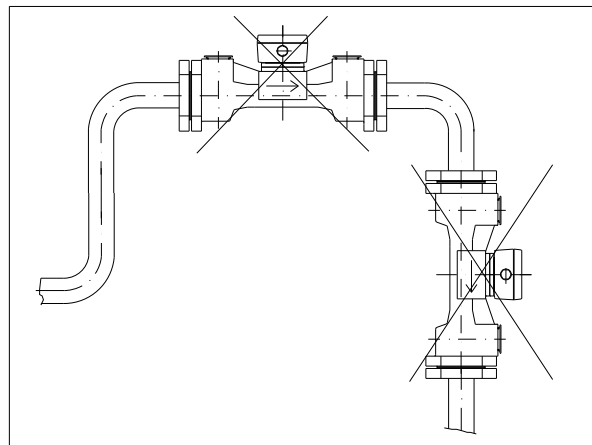

Pressure losses in the flow sensors related to liquid flow velocity are shown in the table in Section 4.2. above.

 ELIS PLZEŇ a. s.	Product application, installation and service manual	Page 18 of 28
	Ultrasonic heat meter SONOTHERM SN3030, SONOTHERM SN3040	

5.3 Data processing electronic unit

In the cases of a commercial meter application, the data-processing electronic unit shall have an independent power supply line 230V, 50Hz with an overcurrent circuit breaker (the recommended rating 6A) that can be sealed in the ON position. Arrangements should be made so that the power supply can only be disconnected by duly authorised staff. The recommended type of power supply cable is CYKY 3 x 1,5mm², outer diameter 10.5mm.

5.4 Resistance temperature sensor

The water temperature measurements can be made using thermometers including resistance temperature sensors Pt 100 or Pt 500, provided such thermometers have been type-tested and approved for use in Czech Republic. The thermometers used in commercial heat/cold meters shall comply with the requirements in Code 505/1990 Coll., be type-approved, metrologically verified by the National Metrological Centre and be supplied in pairs with the temperature reading differences over the whole range of measured temperatures not exceeding 0.05°C. Each temperature sensor shall be connected by two wires.

Temperature sensors Pt 100 and Pt 500

Maximum length of connecting wires: 2.5m for wire cross-section 0.22mm²
 5.0m for wire cross-section 0.50mm²
 7.5m for wire cross-section 0.75mm².

Maximum current loading: 4µA RMS (for sensor Pt 100).



6. METER ASSEMBLY AND INSTALLATION RULES

The meter assembly and installation work shall be done in strict observance of the directions and principles listed in this Manual.

To prevent electric interference, the power cables shall be led at least 25cm away from all signal cables associated with the flow meter (i.e. the coaxial cables connecting sensors UC 3.0 or UC 4.0, the cables from temperature sensors, M-Bus interface signal cables and all input and output impulse signal cables). Should any signal cables need be extended, the connections shall be done by soldering and the soldered joints shall be protected from climatic or mechanical stresses by placing in a suitable installation box. All cables shall be led outside the thermal insulation layers on the water piping. The temperature sensors shall be connected by shielded conductors. The shields shall be connected to the earth potential on one side only, on the terminal board X10 of the electronic accessory.

Sensor must be grounded properly. For grounding use a conductor with minimum cross section area 4 mm^2 and connect the conductor to grounding bolts of evaluation electronic and flow sensor (see figure here below).

Earthing connection between the MTU 2.00 electronic unit and the flow sensor.

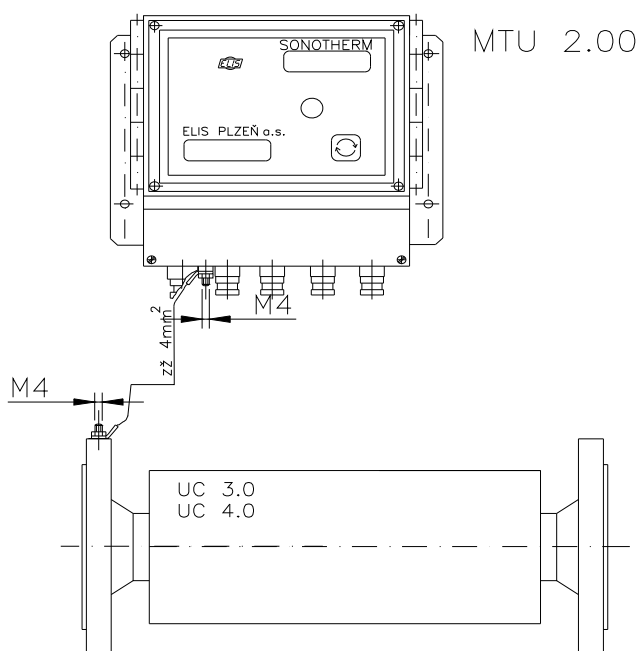

6.1 *Data processing electronic unit MTU 2.00*

The electronic unit shall be mounted in a perpendicular position on a wall or support plate by means of an assembly frame. The electrical connections between the electronic unit and the flow sensor UC 3.0 or UC 4.0 shall be done as described in Section 6.2 below. The difference in lengths of the connecting coaxial cables shall not be greater than 0.1m.

6.2 Electrical connections

Use the schematic drawing below to connect the MTU 2.00 electronic unit to the flow sensor probes. Pay particular attention to the probe 1 and 2 positions with respect to the flow direction.

Schematic drawing of electrical connections between MTU 2.00 and associated devices

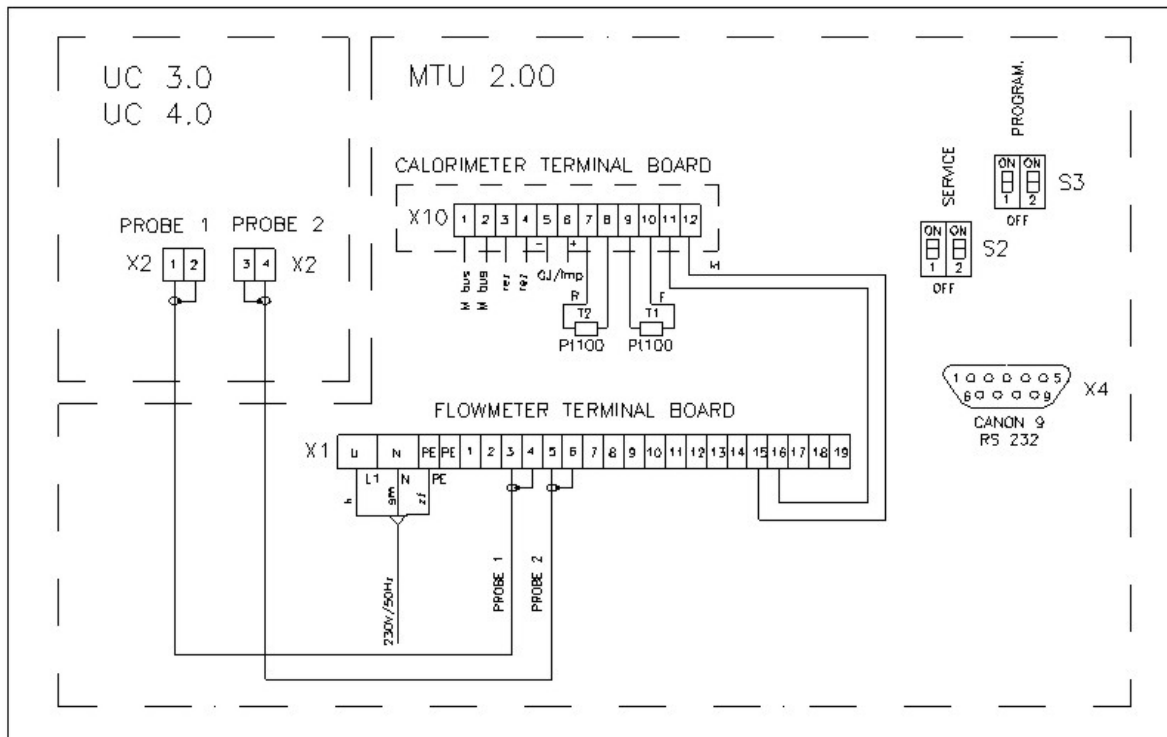

Heating system:

- T1 - thermometer in the feed piping (higher temperature, F)
- T2 – thermometer in the return piping (lower temperature, R)

Cooling system:

- T1 - thermometer in the return piping (higher temperature, R)
- T2 – thermometer in the feed piping (lower temperature, F)

Connection of thermometers Pt100 and Pt500 is identical.

Connector CANON 9 for RS 232 shall be used only for meter servicing purposes.

6.3 Ultrasonic sensors UC 3.0 and UC 4.0

The ultrasonic flow sensor shall be mounted directly on the piping, with the thermal insulation removed. The connecting coaxial cables shall not be attached to the hot-water piping.

When installing the sensor into the piping, make sure that the inner sensor space be completely filled with water at all times. During measurement, water shall not leave the sensor space nor air be allowed to enter it.

If the sensor is mounted in a vertical position, the only permitted water flow direction is upwards. Disregarding the meter installation principles listed in Section 5 may result in measurement errors.

6.4 Mechanical connections

Ultrasonic sensor shall be mounted in the piping using suitable counter-flanges matching the sensor flanges 11 (standard CSN 131160.0). The inner diameter of the counter-flanges and the meter piping shall be identical with the inner diameter of the sensor. The flanges shall be perpendicular to the meter piping axis. The input and output piping shall be perfectly aligned without any protruding edges in contact areas.

The box housing the electronic accessory can be mounted onto a vertical support plate using four bolts of diameter 5 mm.



7. OPERATIONAL START AND METER CONTROL

7.1 Flow metering section

As soon as the flow sensor has been installed in the piping and the electrical connections between the sensor and its electronic unit have been made, the system can be connected to power. Within a short time the flow meter starts its measuring functions.

Connector X4 is reserved for calibration purposes, parameter setting in production and servicing.

Ultrasonic sensor UC 3.0 or UC 4.0 is connected to the associated data processing unit by means of two coaxial cables (see the respective schematic diagram).

If the system is used as a standard meter, switch S3 located under the box lid provided with the official mark and one half of switch S2 are used in production and for metrological purposes. The functions of the remaining half of switch S2 are described in the following table.

Switches S3 and S2: setting combinations		
Measurement mode	S2:1 in position OFF S2:2 in position OFF	S3:2 in position OFF
Servicing mode	S2:2 in position ON	S3:2 in position OFF
Programming mode	S2:2 in position OFF	S3:2 in position ON

7.2 Calorimetric section

As soon as the temperature sensors have been installed and electrically connected, the calorimeter functions can be tested using the respective display code table.

Upon delivery, the calorimeter will be set at the "transport mode" where no measurements are performed and only the real time function is operative. With the transport mode selected, the display shows the word "no" in the upper left corner. To select the "operation mode", depress the display push-button and hold in the depressed position for about 5s.

7.3 Displayed data and information

The upper-line symbol identifies the measured quantity displayed.

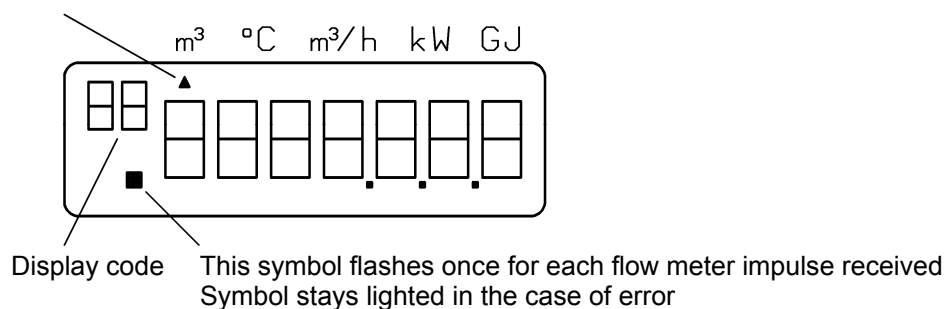

Data and information measured/transferred

- * Accumulated (heat/cold) energy
- * Quantity of impulses at both additional impulse inputs (optional solution on customer order)
- * Error code and duration of actual error
- * Instantaneous power
- * Instantaneous flow rate
- * Input temperature
- * Output temperature
- * Temperature difference
- * Operational period
- * Meter number
- * Production series number
- * Real time and function date
- * Litres per impulse parameter
- * Flow meter location (feed or return piping)
- * Readings on the selected date when the following data are stored in the system memory
 - calendar date
 - accumulated energy
 - accumulated flow volume measured by flow meter
 - accumulated flow volume used in energy calculations
 - accumulated number of impulses at impulse inputs (optional meter configuration)
 - error code (if any) of error occurring at the time of data storage action
- * Accumulated flow volume measured by flow meter
- * Accumulated flow volume used in energy calculations
- * Total period of error duration
- * Previous error code – error type and duration
- * Up to 37 monthly memory registers where each register contains the same type of data as those listed under „Readings on the selected date“
- * Recommended battery replacement date



Display codes on the system LCD in the “operating” and “testing” modes of operation

DISPLAY CODE	DISPLAYED DATA OR INFORMATION	FORMAT
10	Operating mode Accumulated energy	
11	Accumulated flow volume measured by flow meter	
12	LCD test	
13	Impulse register 1 – accumulated value (on customer order)	
14	Impulse register 2 – accumulated value (on customer order)	
15	Error code	
16	Error duration – total time of actual error	Minutes
20	Instantaneous power	
21	Instantaneous flow rate	
22	Input temperature (T1)	
23	Output temperature (T2)	
24	Temperature difference (T)	
30	Readings on selected date Date of memory storage	RRMMDD
31	Accumulated energy	
32	Accumulated flow volume measured by flow meter	
33	Accumulated flow volume used in energy calculations	
34	Impulse register 1 – accumulated value	
35	Impulse register 2 – accumulated value	
36	Error code (any error existing on date of data memory storage)	
37	Total error time (if any)	Minutes
40	Regular monthly readings – date of data memory storage	RRMMDD
41	Accumulated energy	
42	Accumulated flow volume measured by flow meter	
43	Accumulated flow volume used in energy calculations	
44	Impulse register 1 – accumulated value	
45	Impulse register 2 – accumulated value	
46	Error code (any error existing on date of data memory storage)	
47	Total period of error duration (if any)	Minutes
50	Meter operation time	Hours
51	Actual date	RRMMDD
52	Actual time	HHMM
53	Recommended battery replacement date	RRMMDD
60	Communication address	
AX	Meter number	
BX	Production series number	
63	Flow meter impulse input setting – litres per impulse	Litres/impulse
64	Flow meter location in piping branch T2 (L) or T1 (H)	L,H
70	Accumulated flow volume used in energy calculations	
71	Last recorded and communicated value of accumulated energy	
72	Time of last communication	Hour
73	Error duration – total period of actual error duration	Minutes
74	Previous error code	
75	Total period of previous error duration	Minutes

To switch over between code groups, depress the push-button and hold it depressed for longer time. To switch from one code to the next within a code group depress the push-button shortly.

Display format explanation:

RRMMDD RR ... last two digits of year, MM ... month, DD ... day in the month
HHMM HH ... hours, MM ... minutes



Comments/explanations:

- 1) The calorimetric counter has two registers to store data on accumulated flow volume; register 11 contains data on the total accumulated flow volume passed through the flow meter, register 70 contains data on the accumulated flow volume used in heat value calculations. Differences in the data stored in these registers can help identify errors in the temperature sensors whose signals are used for energy calculations.
- 2) To display the next reading on specified date, depress the push-button until you arrive at change of date. After passing through display code 37, the last reading on specified date will be displayed. Then depress the push-button to return to the normal display mode.
- 3) To display the next monthly reading on specified date, depress the push-button until you arrive at change of date. After passing through display code 47, the last monthly reading on specified date will be displayed. Then depress the push-button to return to the normal display mode.
- 4) The right character (X) in the display code AX is a supplementary number to the meter number.
- 5) The right character (X) in the display mode BX is a supplementary number to the production series number.

Error code

There are available three error display modes:

- in display code "15" ... actual error
- in display code "36" ... error existing at the time of data reading and storage
- in display code "46" ... error existing at the time of regular monthly reading.

Error codes

Error code	Type of error
0001	Output thermometer (T2), open circuit
0002	Output thermometer (T2), short circuit
0003	Errors 0001 + 0002 *
0004	Input thermometer (T1), open circuit
0005	Errors 0001 + 0004
0006	Errors 0002 + 0004
0007	Errors 0001 + 0002 + 0004 *
0008	Input thermometer (T1), short circuit
0009	Errors 0001 + 0008
000A	Errors 0002 + 0008
000b	Errors 0001 + 0002 + 0008 *
000c	Errors 0004 + 0008 *
000d	Errors 0001 + 0004 + 0008 *
000e	Errors 0002 + 0004 + 0008 *
000F	Errors 0001 + 0002 + 0004 + 0008 *
0010	Electronic unit (error in EEPROM)
0011 - 001F	Combination of error 0010 and any above error(s)
0020	Electronic unit (error in "Inter-Bus")
0021 - 003F	Combination of error 0020 and any above error(s)
0040	Low flow rate
0041 - 007F	Combination of error 0040 and any above error(s)
0080	Power supply failure - line voltage 230V or bus power
0081 - 00FF	Combination of error 0080 and any above error(s)
0100	Recommended battery replacement date not observed
0101 - 01FF	Combination of error 0100 and any above error(s)

The most frequent errors in the table are printed in bold type. The remaining errors may occur only rarely. Errors marked with "*" will not occur if the electronic accessory works correctly.

Instantaneous values

Instantaneous power value (display code 20) and instantaneous flow rate (display code 21) are calculated only subsequently. If the impulses from the flow meter arrive in intervals longer than 4 seconds, the values of instantaneous power and flow rate are calculated after each new impulse. If this interval is shorter than 4

 ELIS PLZEŇ a. s.	Product application, installation and service manual	Page 25 of 28
	Ultrasonic heat meter SONOTHERM SN3030, SONOTHERM SN3040	

seconds, the impulses are cumulated and the instantaneous value calculations are carried out every 4 seconds.

8. WARRANTY AND POST-WARRANTY SERVICES

8.1 Warranty services

Warranty services are understood to be repairs of products executed free of charge during the contractually agreed warranty period. Such repairs can either be performed at the manufacturer's plant or at that of any authorised partner of the manufacturer.

Warranty repair is understood to be repair of any product defects due to faulty materials, parts or product design, executed free of charge within a period agreed between the customer/user and the meter manufacturer.

Should any meter defect be proved irreparable due to the above reasons, the manufacturer shall replace it by a new faultless product of the same type.

Warranty services can only be performed by the manufacturer (ELIS PLZEN a.s.) or a duly authorised service centre or a product distributor who have received valid authorisation in writing and have been trained in the necessary skills by the manufacturer.

Warranty services shall not be applicable to:

- products with damaged company or metrological seals
- defects due to incorrect product assembly and/or installation
- defects due to incorrect product application
- product theft or pilferage
- defects due to force majeure circumstances

Any requirement regarding warranty services shall be made known to the manufacturer in writing (using E-mail, fax or registered letter). Should the manufacturer not acknowledge the user's warranty claim as justified, it shall inform the user accordingly in writing and invoice to the same the repair costs involved. In the cases of any warranty repairs performed on standard meters, the meter parameters shall consequently be verified at the respective National Metrological Centre.

8.2 Post-warranty services

Post-warranty services are understood to be repairs of any and all product defects originating after the mutually agreed warranty period. Such repair, whether performed at the manufacturer's plant or elsewhere, as directed by the customer, shall be invoiced to the customer who shall be obliged to pay the invoiced sums. In the cases of post-warranty repairs of standard meters, the meter parameters shall consequently be verified at the respective National Metrological Centre. Any requirement regarding post-warranty services shall be made known to the manufacturer in writing (using E-mail, fax or registered letter).

9. TESTING

On every product, the manufacturer performs a detailed inspection of the product completeness and quality in reference to the respective quality assurance standards. Following this inspection the product is subject to tests performed in compliance with the agreed test specifications. Prior to release from the test station, every product is subject to a test run over a minimum period of 15 hours.

10. CALIBRATION AND VERIFICATION

In the cases of standard meters, the manufacturer shall provide for primary verification of the correct design of the flow meter and calorimetric sections at the Authorized Metrological Centre. The ultrasonic flow meter is tested and metrologically verified at three specified operational modes within the required flow rate range. On customer's request and/or in the cases of higher precision requirements, the calibration measurements can be performed at as many as 9 modes within the measuring range.

 ELIS PLZEŇ a. s.	Product application, installation and service manual	Page 26 of 28
	Ultrasonic heat meter SONOTHERM SN3030, SONOTHERM SN3040	

Important notice:

It is recommended that the calibration measurements and verification of the flow meter section of SONOTHERM SN3030, SONOTHERM SN3040 at a certified testing centre be performed on a test stand in a continuous mode of operation.

11. ORDERING

In ordering a product, the customer shall use the enclosed Product Order Form.

12. PACKING

The product packing shall ensure safe domestic and international transport, taking into account the delivery conditions agreed to with the customer. The packing shall comply with the internal standards of the manufacturer (ELIS PLZEN a. s.).

13. PRODUCT ACCEPTANCE

Upon delivery, the goods shall be checked for completeness with respect to the delivery note and subject to visual inspection. A typical scope of delivery includes a complete system SONOTHERM SN3030, SONOTHERM SN3040, operation and maintenance manuals, product compliance certificate and delivery note.

14. WARRANTY CONDITIONS

Unless agreed within the commercial contract otherwise, the standard product warranty period is 12 months from the date of sale. Within the warranty period all product defects due to material and/or part faults shall be repaired free of charge. The warranty period shall be extended by the time the product was inoperative due to a warranty repair. Warranty shall not be applicable to any product defects due to incorrect system assembly and/or installation, intentional damage, pilferage, theft or any faults due to circumstances classified as force majeure.

15. RATING PLATES

Flow sensor plate

Electronic unit plate

ELIS PLZEŇ a.s.					
TYPE		PROD.No.			
DIMENSION DN		m		kg	
PROTEC.		PRESS.PN		MPa	
LIQUID TEMPERATURE		0 ÷ 150		°C	
MEDIUM FLOW DIRECT.		→		CE	

ELIS PLZEŇ a.s.					
TYPE		PROD. No.			
SUPPLY VOLTAGE	230 V/50 Hz				
INPUT POWER	6 W				
PROTECTION	IP 65				

System plate

SYSTEM LABEL		SN3030, SN3040		SERIES NUMBER:				CE	
CERTIFICATE No.				COM. ADDRESS				CLASS OF ACCURACY	
NOMINAL HEAT/COLD RATE				MEASURED SYSTEM				TEMP. SENSOR	
NOMINAL HEAT/COLD DIFFERENCE		°C		Q_{max} OF FLOW METER		m ³ /h		FLOW SENSOR	
MINIMUM HEAT/COLD DIFFERENCE		°C		PLACING OF FLOW METER		piping		PROD. No.	



ELIS PLZEŇ a. s.

Product application, installation and service manual

Ultrasonic heat meter SONOTHERM SN3030,
SONOTHERM SN3040

Page 27 of 28

ELIS PLZEŇ a. s.

Product order form

SN3030, SN3040

Project:	
Measurem. location:	
Project item:	

Required type of system			
Parameter to be specified	Parameter value		Units
Minimum flow rate			m ³ /hour
Maximum flow rate			m ³ /hour
Type of measured liquid			–
Temperature range of measured liquid			°C
Rated pressure of measured liquid	16	40 *	–
Rated inner diameter of sensor UC 3.0, UC 4.0	DN		(see Section 4.1.)
Length of cables to sensor UC 3.0, UC 4.0			m
Placing of flow meter	Feed piping (F) Return piping (R)		–
Communication via M-Bus	Yes	No *	–
M-Bus communic. address (range 1 to 250)	Yes	No *	–
Optional accessories required	Yes	No *	(see Section 4.7.)
Display with illuminated background	Yes	No *	–
Stainless version of sensor UC 3.0	Yes	No *	–
Impulse output - energy	Yes	No *	GJ/imp
Impulse output - volume	Yes	No *	m ³ /imp
Impulse input	Yes	No * imp. number	–
Communication via SIOX-Bus	Yes	No *	–
Alarm signal	Yes	No *	–
Counter flanges, packing and connecting parts and materials	Yes	No *	(Enclose detailed specification)
Flow meter verification in more than three operational modes within the measuring range	Yes	No *	-
Customer address			
Company identification number			
Bank contact			
Contact person			
Telephone		Fax	

Comment: The response time of the accessory electronic unit (if required in any particular application) can be modified on agreement with the customer. The standard meter configuration includes an adaptive filter.

* Cross out if inapplicable



ELIS PLZEŇ a. s.

Product application, installation and service manual

Ultrasonic heat meter SONOTHERM SN3030,
SONOTHERM SN3040

Page 28 of 28

Manufacturer's address:

ELIS PLZEN a. s.
Lucni 15, P. O. BOX 126
304 26 Plzen
Czech Republic
Tel.: +420/377 517 711
Fax: +420/377 517 722
e-mail: sales@elis.cz
<http://www.elis.cz>

Issue No. 1